



COMMERCIAL

Refrigeration Equipment Slide Top Bottle Cooler 65 " Long

ITEM # _____

MODEL # _____

NAME # _____

SIS # _____

AIA # _____



738268 (KCHBC65)

Slide Top Bottle Cooler 65
" Long

Short Form Specification

Item No. _____

Bottle cooler with slide top. Exterior back and side panels in painted steel, exterior bottom panel in galvanized steel, top panel in 304 stainless steel; interior back and side panels in 430 stainless steel, interior bottom panel and worktop in 304 stainless steel. Fin & tube condenser to improve the performances in high temperature environments. Automatic Defrost Cooling System and electronic temperature control.

Vinyl-coated steel adjustable dividers and locking lids.

R600a gas in refrigeration circuit.

ETL Safety and Sanitation certified.

3/5 Years warranty.

Main Features

- Fin & Tube Condenser improves performance in high temperature environments.
- Automatic Defrost Cooling System provides worry-free performance.
- Vinyl-Coated Steel adjustable dividers to customize bottle storage effortlessly.
- Locking doors.
- External temperature display.
- Cabinet completely insulated with high density polyurethane for low environmental impact.
- Locking lids.

Construction

- Pre-wired heavy duty power cord.
- Electronic control to select temperatures.

Sustainability

- CFC and HCFC free (ecological refrigerant type: R600a).
- High efficiency components to minimize the energy consumption still guaranteeing the highest performances.

APPROVAL: _____

Front

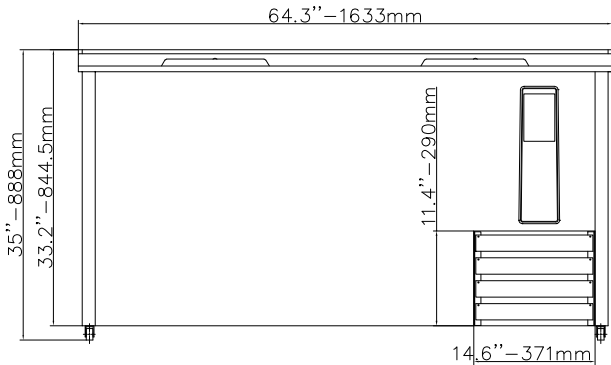

Side

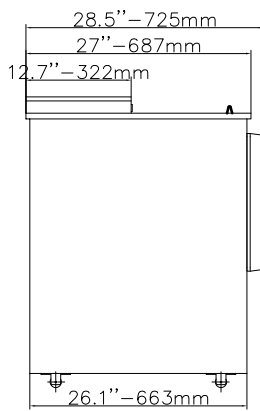

EI = Electrical connection

Top

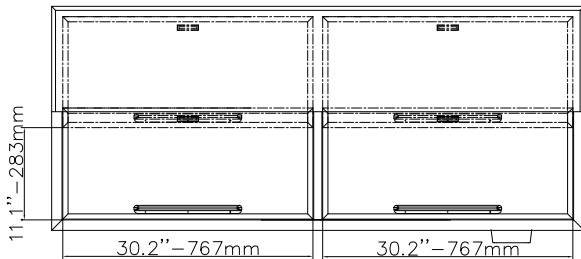

Electric

Supply voltage:

738268 (KCHBC65) 115 V/1 ph/60 Hz

Electrical power, max:

0.31 kW

Plug type:

USA NEMA 5-15P

Capacity:

Gross capacity: 19 cu. feet

Key Information:

External dimensions, Width:	64 5/16" (1633 mm)
External dimensions, Depth:	28 9/16" (725 mm)
External dimensions, Height:	34 15/16" (888 mm)
Internal Dimensions (depth):	26 1/16"
Internal Dimensions (height):	22 15/16"
Internal Dimensions (width):	60 3/8"
Shipping height:	39 3/4" (1010 mm)
Shipping weight:	276 lbs (125 kg)
Shipping volume:	44.34 ft ³ (1.26 m ³)
Type of external material:	Black Prepainted Steel
Type of internal material:	Stainless Steel
Warranty:	3 / 5 years

Refrigeration Data

Compressor Horsepower:	1/6
Operating temperature min.:	32 °F
Operating temperature max.:	41 °F
Condenser type:	Fin & tube

Sustainability

Current consumption:	3 Amps
Refrigerant type:	R600a
Refrigerant weight:	70 g